

# Compool

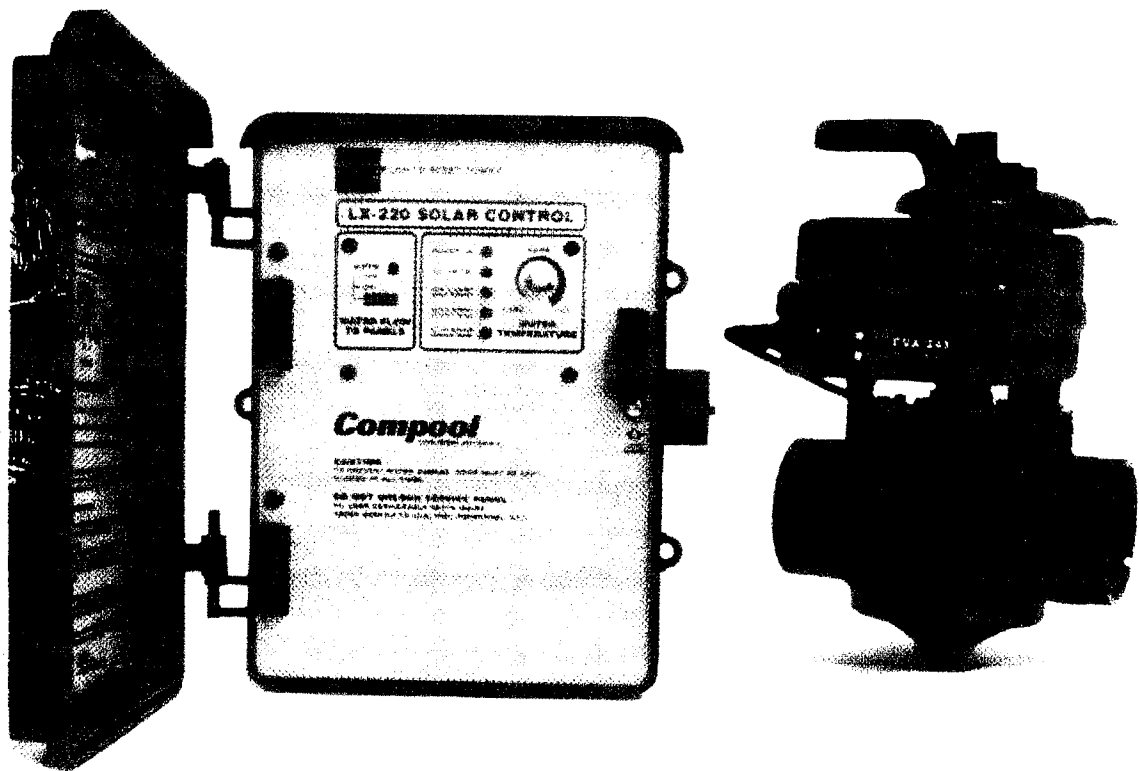

## **Lx220 SOLAR CONTROL SYSTEM**

Installation & Operating Instructions

03/22/00

941-0809C

## **Table of Contents**

Table of Contents .....	1
Safety Notice.....	2
Important Safety Instructions .....	2
Introduction.....	3
Package Contents .....	3
Plumbing Requirements .....	4
Installation Instructions.....	5
Solar Control.....	5
Valve Actuator .....	5
Water Sensor.....	6
Solar Sensor .....	6
High Voltage Wiring .....	6
Pool Cleaner Protection .....	7
Solar Booster Pump Control.....	7
Second Valve Actuator.....	8
System Start-up.....	8
Operating Instructions.....	9
Water Flow To Panels Switch .....	9
Water Temperature Dial .....	9
Power On Light.....	9
Solar On Light .....	9
Pool Cleaner Delay Expired Light .....	9
Water/Solar Sensor Service Required Lights .....	10
Push To Reset Power Button .....	10
Winterizing Instructions .....	10
Problem Solving .....	11
Power On Light Does Not Illuminate.....	11
Solar On Light Does Not Illuminate.....	11
Solar On Light Is Always Illuminated .....	11
Water Flow To Panels Switch Does Not Operate The Valve Actuator .....	11
Checking The Temperature Sensors.....	11
Warranty .....	13
Index .....	14

## **Safety Notice**

### **Important Safety Instructions**

When installing and using this electrical equipment, basic safety precautions should always be followed, including the following:

- ª READ AND FOLLOW ALL INSTRUCTIONS.**
- ª WARNING -** To reduce the risk of injury, do not permit children to use this product unless they are closely supervised at all times.
- ª WARNING -** Water in excess of 100 degrees Fahrenheit may be hazardous to your health.
- ª** A green colored terminal (marked "G") is located inside the high voltage compartment of the LX-220 Solar Control. To reduce the risk of electric shock, this terminal must be connected to the grounding means provided in the electrical supply service panel with a continuous copper wire equivalent in size to the circuit conductors supplying this equipment.
- ª SAVE THESE INSTRUCTIONS.**

## Introduction

The LX220 Control System is a basic differential temperature control designed especially for solar-heated Swimming Pool applications. Whenever solar energy is available, the Control will automatically activate a motorized three-port Solar Valve and/or a Solar Booster Pump.

Remember to set the filter pump timer so that the filter pump is operating during that time of the day when solar energy is available.

If the Swimming Pool utilizes a pool cleaner booster pump, the Control will optionally disable the pump for a period of 4 minutes whenever the solar system turns on. This protects the pump from possible damage caused by residual air within the solar panels.

## Package Contents

The LX220/2TX Solar Valve Control System includes the following components:

LX-220 Solar Control

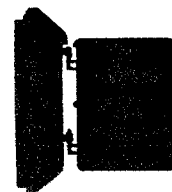

CVA-24T Valve Actuator



PTV-2TS 3-Port Valve



TS-5T Temperature Sensor (2 qty.)



Note: The System is also available without Valve and Valve Actuator. Order LX220/B Solar Booster Pump System.

Tools Required: 5/16" Drill for Water Sensor. Cable for Solar Sensor.

## Plumbing Requirements

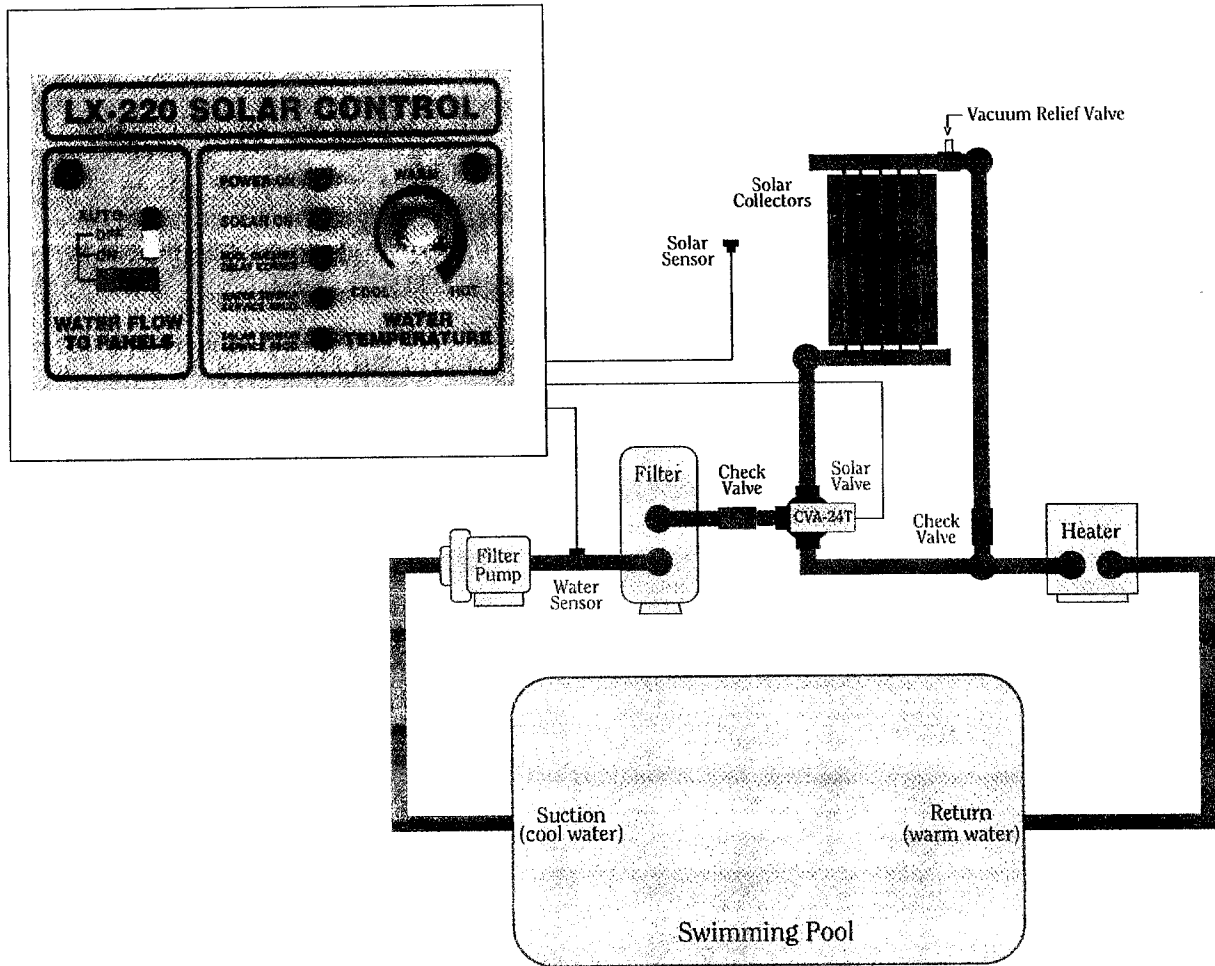

Plumb system in accordance with recommended hydraulic schematic.

2" dia. plumbing is advised to ensure maximum flow of water through the solar panels. A solar booster pump should be added if panels are installed at a very high elevation.

It is recommended that the solar panels are mounted in a way that gravity will allow draining whenever the filter pump is not on.

For systems with glazed panels, damage can occur from overheating if the filter pump is still running after the solar has turned off. To enable glazed panels to automatically drain whenever the solar turns off (even if the filter pump is still running), a 1/2" motorized Solar Drain Valve (model HW-5B) should be plumbed from the solar feed line, through a check valve, to a zero psi point (such as pool fill line or jet air intake).

## Installation Instructions

### Solar Control

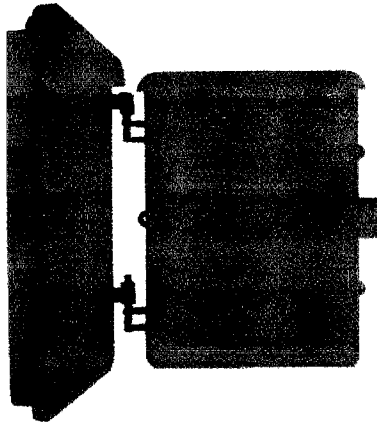

Select a convenient location to mount the Control, making sure that the location is greater than 5 feet from the Pool or Spa and no further than 15 feet from the Solar Valve. Wall-mount the Control, using appropriate screws through the three external mounting points located on the side of the enclosure.

### Valve Actuator



Mount Valve Actuator to solar valve using the 4 mounting screws provided. Run cable to solar control. Loosen LOCK SCREW on service panel of Solar Control, and swing open to expose the high voltage and low voltage compartments. Insert Valve Actuator cable through hole on bottom left side of Solar Control, and plug into circuit board at VLVI socket.

## Water Sensor

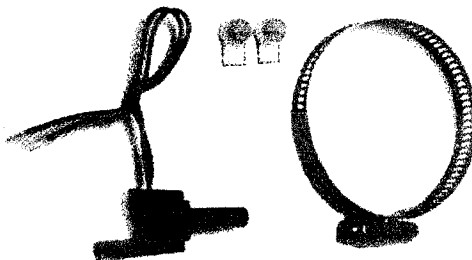

Select a convenient location to mount the Water Sensor in the plumbing system between the filter pump and filter. Drill a 5/16" dia. hole in one side of pipe, and install one of the Temperature Sensors (included) in accordance with instructions provided. Run 22 gauge 2-conductor cable (included) between the Sensor and low voltage compartment of the Solar Control. Use waterproof connectors (provided) to connect Sensor to cable. At the Solar Control, strip insulation 1/4" and connect to the circuit board at WATER SENSOR screw terminals.

## Solar Sensor

Install the other Temperature Sensor at the solar panel array, or any sunny location.

**WARNING: DO NOT DRILL HOLE AND CLAMP SENSOR INTO SOLAR PIPE.** For glazed panels, install Sensor between collector and glazing. Run 2-conductor cable between the Sensor and the Solar Control. Use waterproof connectors (provided) to connect Sensor to cable. At the Solar Control, strip insulation 1/4" and connect cable to the circuit board at SOLAR SENSOR screw terminals.

## High Voltage Wiring

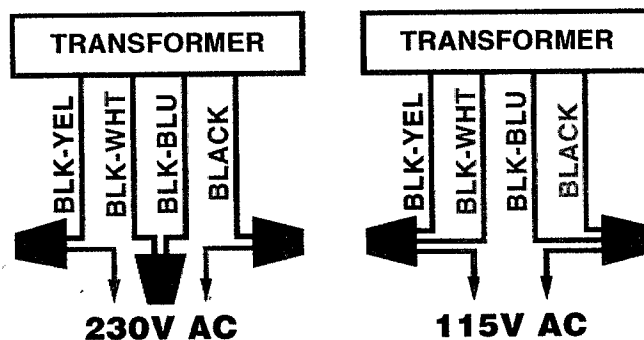

The high voltage wiring section is located behind the service panel in the lower right side compartment of the Solar Control. Holes are provided on bottom of enclosure for conduit mounting. The Solar Control can be connected either to 115VAC or 230VAC. The Solar Control should be wired so that it gets continuous power (connect to Line-Side of Time Clock or directly to sub-panel).

**Pool Cleaner Protection**

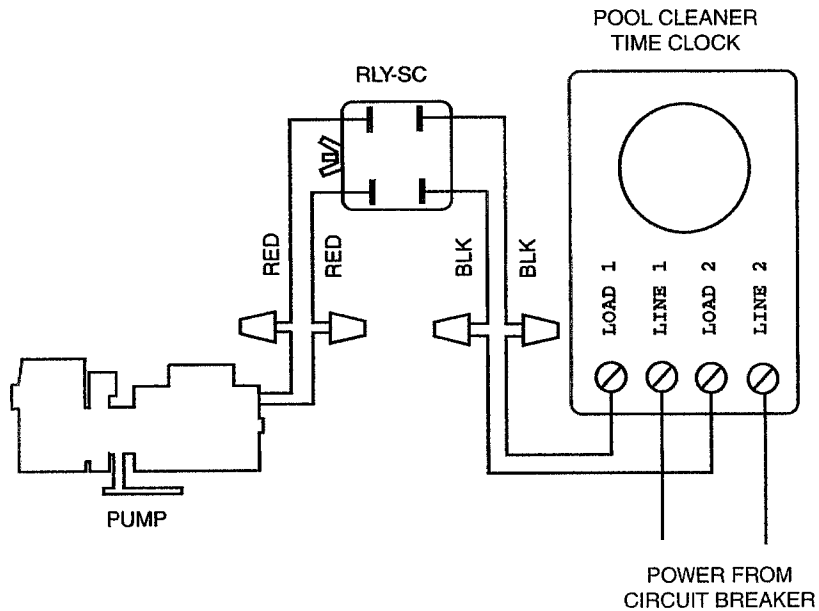

Recommended for use in pool systems which utilize a “booster pump” pool cleaner. This feature automatically turns off the pool cleaner pump for a few minutes whenever solar is initiated. This will protect the pump from damage caused by air in the solar panels at system start-up.

Install Relay Kit (model RLY-SC) at the Solar Control in accordance with instructions provided, and plug low-voltage connector onto circuit board at SWP Socket. Using wire nuts, connect Black wires to Load connections of Pool Cleaner Time Clock, and connect Red wires to the Pool Cleaner Pump.

**Solar Booster Pump Control**

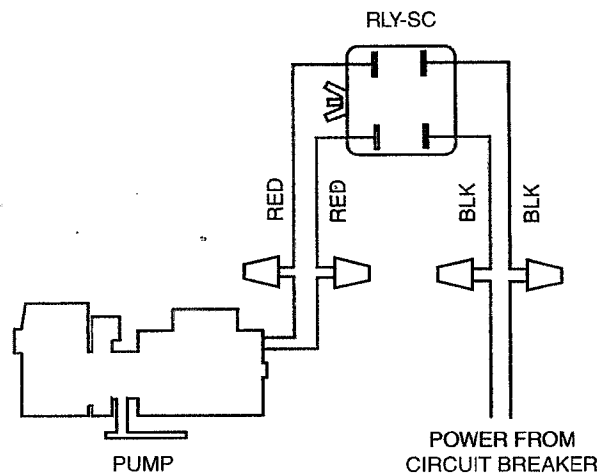

If a solar booster pump is being used, install a Relay kit (model RLY-SC) at the Solar Control in accordance with instructions provided.

Plug low-voltage connector onto circuit board at PMP Socket. Using wire nuts, connect Black wires to 115VAC or 230VAC Line Voltage, and connect Red wires to the Solar Booster Pump.



### Second Valve Actuator

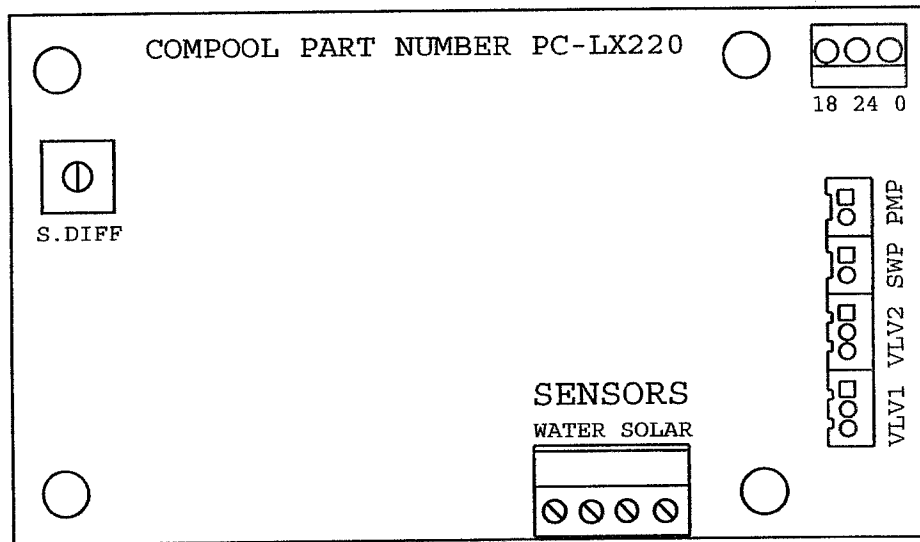

It is possible to control a maximum of two Valve Actuators. Plug the second Valve Actuator into VLV2 socket.

### System Start-up

Apply power to the system.

Place the WATER FLOW TO PANELS Switch in the "OFF" position. The POWER ON and POOL CLEANER DELAY EXPIRED Lights should come on.

If pool cleaner protection has been added to the system, the pool cleaner pump motor should be activated whenever the pool cleaner timer is on. Momentarily turn pool cleaner timer on and off to check that the motor is operating correctly.

Check that Solar Valve is in "solar bypass" position, diverting water away from solar panels. If Solar Valve is staged incorrectly (ie: diverting water to the solar panels), reverse switch on back of Valve Actuator (change from ON1 to ON2, or vice-versa). The Valve Actuator will automatically rotate to the correct position.

Place the WATER FLOW TO PANELS Switch in the "ON" position. The POOL CLEANER DELAY EXPIRED Light will turn off, and the SOLAR ON Light will come on. Check that Solar Valve has rotated from the "solar bypass" position to the "solar" position, diverting water through the solar panels.

Place the WATER FLOW TO PANELS Switch in the "AUTO" position.

The system is now ready to be operated as desired.

## Operating Instructions



### Water Flow To Panels Switch

**AUTO:** Automatically turns system on whenever solar energy is available. Switch should be left in this position during normal use.

**OFF:** Manually turns solar system off.

**ON:** Manually turns solar system on, regardless of solar availability. This position should be used only to test system operation.

### Water Temperature Dial

Allows solar system to heat the water up to set temperature. After that temperature is reached, the solar system is automatically turned off. The Dial ranges from approximately 74 - 110 degrees Fahrenheit

To determine your optimum temperature setting, set Dial to the "HOT" position and observe the water temperature over a period of a few days. When the maximum desired temperature of the pool is reached, rotate the Dial counterclockwise until the SOLAR ON Light just goes out. Once this setting is identified, it will not be necessary to change the Dial.

### Power On Light

When Lit, indicates that electrical power is applied to the Control.

### Solar On Light

When lit, indicates that solar system is on. **Note:** the filter pump timer must be set so that the filter pump operates during that time of the day when solar energy is available.

### Pool Cleaner Delay Expired Light

Whenever the solar system is turned on, an electronic delay automatically turns off the pool cleaner for a few minutes. This protects the pump from damage caused by air in the solar panels at system start-up. **Note:** to enable this feature, an optional Relay Kit (model RLY-SC) must be added to the Control. This light indicates that the delay has expired.

**Water/Solar Sensor Service Required Lights**

The Control incorporates electronic Sensors to monitor the water and solar temperatures. If a Sensor should malfunction or the cable to the Sensor become damaged, the appropriate SENSOR SERVICE REQUIRED Light will come on. This indicates that the Sensor and its wiring connections should be inspected by your Pool Serviceperson.

Replace defective Sensor with 10K Thermistor Sensor (Compool model TS-5T).

**Push To Reset Power Button**

An internal circuit breaker protects the Solar Valve and control circuitry from electrical overload situations. A tripped breaker is indicated by a white tab. Check for short circuit conditions before resetting. Push to reset.

**Caution:** Do not attempt to pry out tab.

**Winterizing Instructions**

Each year, at the onset of winter, it is advisable to remove all water from the solar system, and prevent any new water from entering the solar panels during the winter months.

To disable the Solar Control during the winter months, place the WATER FLOW TO PANELS Switch in the OFF position.

**Note:** Freeze damage is not covered under System Warranty.

## Problem Solving

### Power On Light Does Not Illuminate

Verify the circuit breaker at sub-panel is not tripped. If the 3-amp Circuit Breaker on the LX-220 is tripped, it is most often due to a defective Circuit Board or Valve Actuator. Try disconnecting each one separately to determine which one is at fault.

### Solar On Light Does Not Illuminate

The SOLAR ON light will only illuminate when the solar temperature is 5 degrees warmer than the water temperature.

Check the SENSOR SERVICE REQUIRED Lights on the LX-220 Solar Control. If either Light is illuminated, inspect the appropriate cable and wire connections and replace the appropriate Temperature Sensor if necessary. An ohm meter can be used to take a reading of the Sensors. See Table 1.

If the Temperature Sensors are not at fault, replace the Circuit Board.

### Solar On Light Is Always Illuminated

Check the SENSOR SERVICE REQUIRED Lights on the LX-220 Solar Control. If either Light is illuminated, inspect the appropriate cable and wire connections and replace the appropriate Temperature Sensor if necessary. An ohm meter can be used to take a reading of the Temperature Sensors. See Table 1.

If the Temperature Sensors are not at fault, replace the Circuit Board.

### Water Flow To Panels Switch Does Not Operate The Valve Actuator

If the Valve Actuator does not operate when using the WATER FLOW TO PANELS Switch (sliding switch between ON and OFF), either the Valve Actuator or the Circuit Board is at fault.

First verify that the toggle switch located on the Valve Actuator is either in the ON1 or ON2 position.

With a voltmeter, check the output voltage of the VLV1 socket located on the LX-220 Circuit Board. When the WATER FLOW TO PANELS Switch is in the OFF position, the top and middle pins should read 24 VAC. When the WATER FLOW TO PANELS switch is in the ON position, the top and bottom pins should read 24 VAC.

If voltage readings are correct, replace the Valve Actuator. If voltage readings are incorrect, - replace the Circuit Board.

### Checking The Temperature Sensors

Disconnect Temperature Sensor wires from the circuit board, and test sensor using an ohm meter. See Table 1.

**Table 1:**

<b>DEG. F</b>	<b>OHMS</b>
30	34574
35	30008
40	26109
45	22771
50	19906
55	17440
60	15314
65	13477
70	11884
75	10502
80	9299
85	8250
90	7333
95	6531
100	5827
105	5208
110	4663
115	4183
120	3758
125	3382
130	3048
135	2752

## Warranty

Compool, Inc. warrants to the purchaser of this electronic control system, for the period of one year from the date of original purchase for use, that any defective product proved to be caused by faulty workmanship or faulty material, will be repaired or replaced at Compool's option at no charge, providing the product is returned to Compool with all transportation charges prepaid.

This warranty covers the Solar Control and Valve Actuator. It extends to the first retail purchaser and any subsequent owners of the system.

This limited warranty applies only to controls which have been installed and maintained in strict accordance with installation and operating instructions provided by Compool, Inc., using installation hardware supplied and/or recommended in writing by Compool, and to controls which have been connected to the correct supply voltage.

This limited warranty does not apply to any controls which have been repaired or altered by anyone other than Compool or a person authorized by it; or which have been subject to misuse, neglect or accident; or which have been damaged by wind, rain, lightning, freezing or other cause, thing, person, or act of God; or which have been subject to damage in transit, during installation, or by someone other than Compool, Inc.; or which have been damaged because of a defect in a component or part which is not part of the Compool Control System; or upon which the serial number or manufacture date has been altered, effaced or removed.

This warranty gives you specific legal rights and you may also have other rights which vary from State to State. Compool, Inc. does not authorize any person to create any other obligation or liability in connection with Compool controls.

Compool, Inc. makes no warranty of merchantability or fitness for any use. Any implied warranty applicable to Compool controls is limited in duration to the duration of this written warranty. Unless state law provides otherwise, Compool, Inc. shall not be liable for consequential or incidental damages resulting from breach of this written warranty or any implied warranty, or any inconvenience, loss of time, or incidental expenses such as telephone calls.

Compool, Inc. shall not be liable for any labor charges associated with the removal or reinstallation of any so-claimed defective products.

To exercise this warranty, send defective parts, with copy of dated receipt and a brief description of the problems encountered, postage prepaid, to:

Compool, Inc.  
599 Fairchild Drive  
Mountain View, California 94043

For questions, repairs, replacement parts, or information on possible Authorized Service Centers within your vicinity call:

Compool, 800-458-2201 or 650-964-2201, Monday - Friday, 8:00 - 5:00 Pacific Time.

Or visit us on the internet at [compool.com](http://compool.com)